



EUROPEAN UNION



GOVERNMENT OF ROMANIA



SERBIAN GOVERNMENT



Structural Funds
2007-2013



ECOSOLDER

Romania - Republic of Serbia IPA Cross-border Cooperation Programme

ECOSOLDER



Romania-Serbia

Common borders. Common solutions.



EUROPEAN UNION



GOVERNMENT OF ROMANIA



SERBIAN GOVERNMENT



Structural Funds
2007-2013



ECOSOLDER

Romania - Republic of Serbia
IPA Cross-border Cooperation Programme
VENTILACIJA PROIZVODNIH HALA, LIVNICA I
LABORATORIJA

“ADMETAL” BOR
VENTILATION OF PRODUCTION FACILITIES IN FOUNDRIES
AND LABARATORIES

“ADMETAL” BOR

SERBIA



Romania-Serbia

Common borders. Common solutions.



EUROPEAN UNION



GOVERNMENT OF ROMANIA



SERBIAN GOVERNMENT



Structural Funds
2007-2013



ECOSOLDER

PROIZVODNI PROGRAM



Portal.Ink



Romania-Serbia

Common borders. Common solutions.



EUROPEAN UNION



GOVERNMENT OF ROMANIA



SERBIAN GOVERNMENT



Structural Funds
2007-2013



ECOSOLDER

- VENTILACIJA I PREČIŠĆAVANJE GASOVA
- Ventilacija proizvodnih pogona može biti centralna, gde se vrši potreban broj izmena po času. Vazduh se filtrira, po potrebi pothlađuje i ovlažuje i takav ubacuje u pogon.
- Druga varijanta je ventilacija po radnim mestima, gde se lokalno odvodi zaprljan vazduh



Romania-Serbia

Common borders. Common solutions.



EUROPEAN UNION



GOVERNMENT OF ROMANIA



SERBIAN GOVERNMENT



Structural Funds
2007-2013



ECOSOLDER

- prečišćava i izbacuje u atmosferu. Ovaj način ventilacije ima veliku primenu tamo gde imamo lokalne izvore prašine, i posebno gde se u procesu rada oslobađaju toksične materije.
- Ventilacija mesta gde se stvaraju toksični gasovi mora biti u potpuno zatvorenom radnom prostoru, gde se gasovi posle pranja i neutralizacije izbacuju u atmosferu.



Romania-Serbia

Common borders. Common solutions.



EUROPEAN UNION



GOVERNMENT OF ROMANIA



SERBIAN GOVERNMENT



Structural Funds
2007-2013



ECOSOLDER

- **PRIMER** : Laboratorija sa sistemom digestor skruber za pranje gasova i rezervoar sa sredstvom za pranje i neutralizaciju, i ventilator za izvlačenje i vođenje gasova kroz sistem i izbacivanje prečišćenih gasova u atmosferu. Ako gasovi posle prečišćavanja i neutralizacije zadrže mirise, tretiraju se aktivnim ugljenikom pre izbacivanja u atmosferu.



Romania-Serbia

Common borders. Common solutions.



EUROPEAN UNION



GOVERNMENT OF ROMANIA



SERBIAN GOVERNMENT



Structural Funds
2007-2013



ECOSOLDER

- **PRIMER: Ventilacija radnog mesta kod elektrolučnog zavarivanja.**

- Firma “ADMETAL”uradila je sistem za ventilaciju četiri radnih mesta za ručno brušenje i poliranje umetničkog liva - skulptura, statua, reljefa, gde su sva četiri radna mesta povezana na jedan sistem multiciklona i filtera.
- Iz navedenih preporuka za konstrukciju haube, količinu i brzinu vazduha za elektrolučno zavarivanje i ručno poliranje vidimo da su isti za oba sistema što znači da sistem možemo da primenimo za obe namene.



Romania-Serbia

Common borders. Common solutions.



EUROPEAN UNION



GOVERNMENT OF ROMANIA



SERBIAN GOVERNMENT



Structural Funds
2007-2013



ECOSOLDER

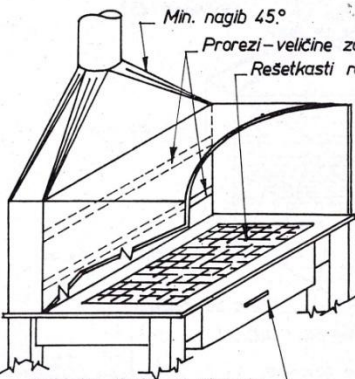

Pokretna fioka za čišćenje
 $Q = 30 \text{ m}^3/\text{min}$. po m^2 otvorene čeonog površine.
Brzina u vodu = $10 \text{ m}/\text{sek}$.
Gubitak na ulazu = $1,78 \text{ Pd}$ proreza
+ $0,24 \text{ Pd}$ voda.

DRUGI TIPOVI HAUBA

Kabina:
 $Q = 30 \text{ m}^3/\text{min}$. po m^2 čeonog otvora
Videti „kabine za bojenje“ VS-603,
VS-604 „kabina za metalizaciju“ VS-415

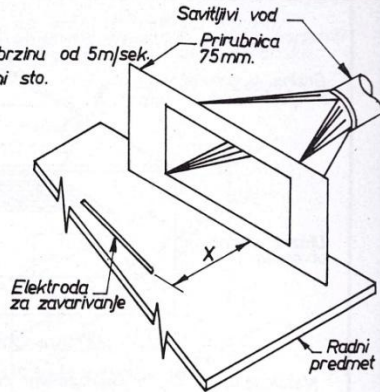

ISISAVANJE SA PRENOSNOM HAUBOM

X, mm	m^3/min
150	7,1
225	11,4
300	18,3

Ulazna brzina = $7,5 \text{ m}/\text{sek}$.
Brzina u vodu = $15 \text{ m}/\text{sek}$. minimum.
Gubitak na ulazu = $0,50 \text{ Pd}$.
Videti i "Rezanje granita" VS-906

OPŠTA VENTILACIJA, tamo gde ne može koristiti lokalna ventilacija:

prečnik elektroda, mm	m^3/min . po varijaci
4	28,3
5	42,5
6,3	97,2
10	127,5

x Za toksične materije neophodni su veći protoci vazduha.

LEMLJENJE I LUČNO ZAVARIVANJE

VS - 416

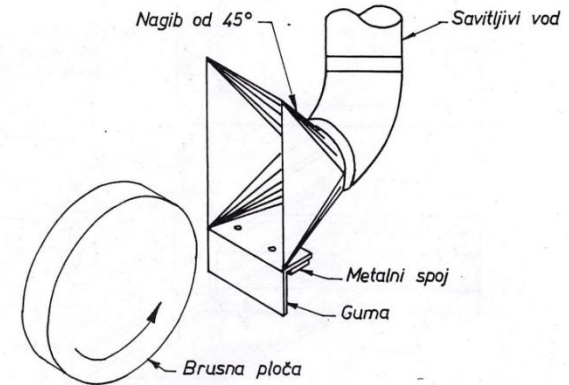

$Q = 6,3 \text{ m}^3/\text{min}$, za brusne ploče prečnika do 125mm.
 $8,6 \text{ m}^3/\text{min}$, za brusne ploče prečnika 125 do 250mm.
Gubitak na ulazu = $0,25 \text{ Pd}$.
Brzina u vodu $17,5 \text{ m}/\text{sek}$. - minimum.



CROSS
BORDER
COOPERATIO

Romania-Serbi

Common borders. Common solutions...

POVRŠINSKO BRUŠENJE

VS - 417



EUROPEAN UNION



GOVERNMENT OF ROMANIA



SERBIAN GOVERNMENT



Structural Funds
2007-2013



ECOSOLDER

Thank you for your attention!



Romania-Serbia

Common borders. Common solutions.